

THIS DRAWING IS UNPUBLISHED. RELEASED FOR PUBLICATION
 © COPYRIGHT - BY TYCO ELECTRONICS CORPORATION. ALL RIGHTS RESERVED.

LOC	DIST	REVISIONS			
P	LTR	DESCRIPTION	DATE	DWN	APVD
CM	00	J	REVISED PER 0G3B-0871-03	05NOV03	KW DC

1. PACKAGED IN HEAT SEALED 3 MIL POLYBAG.
2. MIL NO. MS3367-5.

UNIT OF MEASURE	A	B	C	D	E	L		MAX BUNDLE DIAMETER	MIN TENSILE STRENGTH
INCHES	.232	.236	.142	.169	.043	5.83		1.25	30 LBS
MM	5.9	6.0	3.6	4.28	1.1	148		31.75	13.608 KG

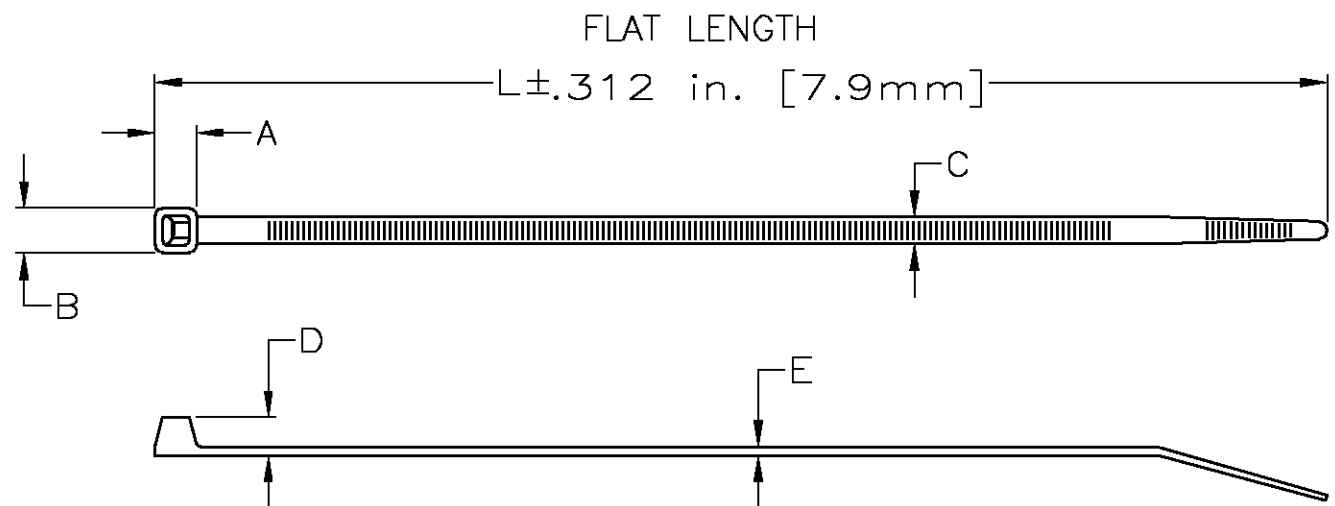

QTY/BAG	COLOR	PART NUMBER
1000	NATURAL	2-603227-9
1000	BLACK	2-603227-0
1000	NATURAL	1-603227-9
100	BLACK	1-603227-0
1	NATURAL	603227-2
1	BLACK	603227-1

THIS DRAWING IS A CONTROLLED DOCUMENT.		DWN B. POWELL 10AUG95	Tyco Electronics Corporation Harrisburg, PA 17105-3608	
DIMENSIONS: INCHES		CHK D. KAAT 10AUG95		
		TOLERANCES UNLESS OTHERWISE SPECIFIED:		PRODUCT SPEC -
MATERIAL NYLON 6/6		FINISH -		APPLICATION SPEC -
		APVD -		RESTRICTED TO -
		WEIGHT -		SIZE A3
		CUSTOMER DRAWING		CAGE CODE 00779
		SCALE 1:1		DRAWING NO C-603227
		SHEET 1 OF 1		REV J